

DESIGN AND ANALYSIS OF MICRO GRID DISTRIBUTION SYSTEM USING APF WITH PI CONTROLLER FOR HARMONIC REDUCTION

¹SHAIK NABEEN SHAIDA, ²CH RAMI REDDY

¹M.Tech, NALANDA INSTITUTE OF ENGINEERING & TECHNOLOGY

²Assistant Professor, NALANDA INSTITUTE OF ENGINEERING & TECHNOLOGY

ABSTRACT: According to the distribution systems, whenever the load increase or decreases suddenly which is such as nonlinear loads which causes the load harmonics and reactive power and draw non-sinusoidal currents from the AC mains and also excessive neutral currents in power systems that arise pollution. Due such pollution problems which is created in power systems by the nonlinear characteristics and fast switching of power electronic devices, current controlled PWM converters are seen as a most viable solution which is depend upon the Shunt active filter. In this paper three phase four wire micro-grid distribution system is presented that use IP controlled shunt active to reduce the harmonics and reactive power from the system. The technique which is used to generate desired compensation current extraction based on offset command instantaneous currents distorted or voltage signals in the time domain. Compensation time domain response is quick, easy to implement and offer lower computational load.

Keywords— Voltage Disturbances, Nonlinear Loads, PCC, Power Quality, Shunt Active Power Filter (SAPF), PWM.

INTRODUCTION

Power pollution has been introduced into distribution systems by nonlinear loads such as transformers, computers, saturated coils and increases sophisticated power electronic devices in delay use. Due to its nonlinear characteristics and fast switching, power electronics devices create most of the pollution issues. By increasing in such non-linearity causes many problem like low system efficiency and poor power factor. It also affect to other consumers. Hence it is very important to overcome these undesirable features. The shunt passive filters consist of tuned LC filters and high passive filters are used to suppress the harmonics. The power capacitors are employed to improve the power factor. But they have the limitations of fixed compensation, large size and can also exile resonance conditions. So active power filters are now seen as a best alternative over the classical passive filters, to compensate harmonics and reactive power requirement of the non-linear loads.

Various topologies of active power filters have been developed so far [1-11]. The shunt active power filter based on current controlled voltage source type PWM converter has been proved to be effective even when the load is highly nonlinear [1].

Most of the active filters developed are based on sensing harmonics. However, the conventional PI controller was used for the generation of reference current template. The PI controller requires precise linear mathematical models, which are difficult to obtain and fails to perform satisfactorily under parameter variations, nonlinearity, load disturbance, etc.

In this work PI controlled shunt active power filter implemented for the harmonics and reactive power compensation of a nonlinear load are. The control scheme is based on sensing line currents only and approach different from convention ones. The DC capacitor voltage is regulated to estimate the reference current template from system. The role of the DC capacitor is described to estimate the reference current. A design criterion is described for the selection of power circuit components. Both the control schemes are compared and performance of both the controllers is investigated. A detailed simulation program of the schemes is developed to predict the performance for different conditions and Simulink models also has been developed for the same for different parameters and operating conditions.

MODELLING OF CASE STUDY POWER FILTER TOPOLOGIES:

Depending on the system application or electrical problem to be solved, active power filters can be implemented as shunt type, series type, or a combination of shunt and series active filters. These filters can also be combined with passive filters to create hybrid power filters.

The shunt-connected active power filter shows the characteristics similar to STATCOM (reactive power compensator of power transmission system) when used with self-controlled dc bus. The shunt active power filters, acts as a current source, injects harmonic compensating current of same magnitude as the load current harmonics but shifted in phase by 180° and thus compensates load current harmonics.

The series-connected filter mainly compensates voltage unbalances and sags/swell from the ac supply and thus protects consumer from inadequate voltage quality. These are used for low-

power applications. These filters can be used as a substitute to UPS with comparatively very low cost as no energy storing element like battery is used. Moreover overall rating of components is smaller.

The series active filters work as hybrid filter topologies with passive LC filters. In case passive LC filters are reconnected in parallel to the load then series active power filter operates as a harmonic isolator and forcing the load current harmonics to circulate mainly through the passive filter rather than the power distribution system. The main advantage of this topology is that the rated power of the series active filter is a small fraction of the load kVA rating.

In series-shunt active filter the shunt active filter is located at the load side and can be used to compensate for the load harmonics, reactive power, and load current unbalances. And the series filter is at the source side and can act as a harmonic blocking filter. This series-shunt active filter topology has been called the Unified Power Quality conditioner. Multilevel inverters are based on hybrid AC filter and recently used for active filter topologies. Three phase four wire inverters are becoming very popular for most inverter applications like machine drives and power factor compensators. The benefit of multilevel converters is that they can decrease the harmonic content generated by the active filter because multilevel converters can produce more levels of voltage than other converters. This feature helps to reduce the harmonics generated by the filter power itself. One more advantage is that they can reduce the voltage or current ratings of the semiconductors and the switching frequency requirements.

VOLTAGE SOURCE CONVERTERS:

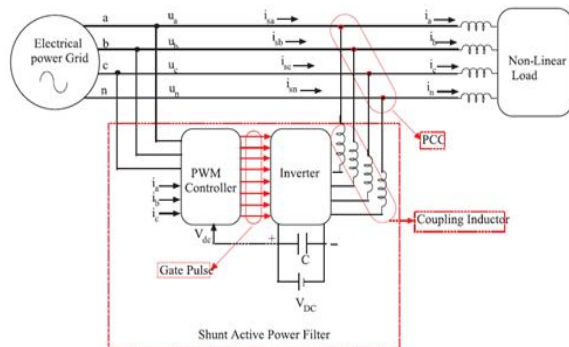

Fig.1 Shunt active power filters topology.

The active power filter topologies mostly use as voltage source converters. This topology, shown in Figure 1, converts a dc voltage into an ac voltage by appropriately gating the power semiconductor switches. A single pulse for each half cycle can be applied to synthesize an ac voltage. For these purposes most applications requiring dynamic performance, pulse width modulation is the most commonly used for active power filter. PWM

techniques applied to control the VSI for consist of chopping the dc bus voltage to produce an ac voltage of an arbitrary waveform.

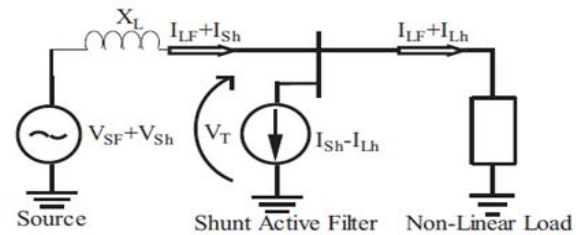

Fig.2 Principle of Shunt Current Compensation

Voltage source converters are preferred over current source converter because it has higher efficiency and lower initial cost than the current source converters [3, 4, 9]. They can be readily expanded in parallel to increase their combined rating and their switching rate can be increased if they are carefully controlled so that their individual switching times do not coincide. Therefore, higher-order harmonics can be eliminated by using converters without increasing individual converter switching rates. Because of nonlinear load current will have harmonics, so load current will be the summation of fundamental and all other harmonics, all harmonics will be integer multiple of fundamental frequency. Load current can be written as

$$i_L(t) = \sum_{n=1}^{\infty} i_n \sin(n\omega t + \varphi_n) = i_1 \sin(\omega t + \varphi_1) + \sum_{n=2}^{\infty} i_n \sin(n\omega t + \varphi_n) \quad (1)$$

Instantaneous Load can be written as

$$p_L(t) = v_s(t) * i_L(t) \quad (2)$$

Putting value of $i_L(t)$ from equation (1) in equation (2)

$$p_A(t) + p_R(t) + p_H(t) \quad (3)$$

Here $p_A(t)$ is active or fundamental power. Only fundamental component of voltage and current can deliver power to the load and $p_R(t)$ is reactive power. Harmonic power denoted by $p_H(t)$. So active or real power drawn by the load from the source is

$$p_A(t) = v_m i_1 \sin^2 \omega t * \cos \varphi_1 = v_s(t) * i_s(t) \quad (4)$$

Therefore, source current after compensation will be given by equation (5)

$$i_s(t) = \frac{p_A(t)}{v_s(t)} = i_1 \cos \varphi_1 * \sin \omega t = i_m \sin \omega t \quad (5)$$

In a practical converter, there are switching, conducting and capacitor leakage losses. So that losses must be supplied by the supply or by the grid itself. So total current supplied by supply will be given as

$$i_{SP} = i_m + i_{slo} \quad (6)$$

Where i_{sp} = peak current supplied by source. Where i_{slo} = loss current of converter supplied by the source. If total harmonic and reactive power of the load is supplied, by the Active Power Filter then

there will not be any harmonic in source current and source current will be in phase with the source voltage. Therefore, the total source current including losses will be given as $i_s^* = i_{sp} \sin \omega t$. So compensating current will be given as

$$i_c(t) = i_L(t) - i_s^*(t) \quad (7)$$

It is obvious from above discussion that for instantaneous compensation of reactive power in addition, harmonic power, source (grid) should be able to supply current i_s^* .

ESTIMATION OF REFERENCE SOURCE CURRENT:

The instantaneous currents can be written as

$$i_s(t) = i_L(t) - i_c(t) \quad (8)$$

Source voltage is given by

$$v_s(t) = v_m \sin \omega t \quad (9)$$

If a non-linear load is applied, then the load current will have a fundamental component and harmonic components which can be represented as

$$i_L = \sum_{n=1}^{\infty} i_n \sin(n\omega t + \phi_n) = i_1 \sin(\omega t + \phi_1) + \sum_{n=2}^{\infty} i_n \sin(n\omega t + \phi_n) \quad (10)$$

The instantaneous load power can be given as

$$P_L(t) = v_s(t) * i_L(t) = v_m I_1 \sin^2 \omega t * \cos \phi_1 + v_m I_1 \sin \omega t * \cos \omega t * \sin \phi_1 + v_m \sin \omega t * \sum_{n=2}^{\infty} i_n \sin(n\omega t + \phi_n) \quad (11)$$

$$= p_f(t) + p_r(t) + p_h(t) \quad (12)$$

From (11), the real (fundamental) power drawn by the load is

$$p_f(t) = v_m I_1 \sin^2 \omega t * \cos \phi_1 = v_s(t) * i_s(t) \quad (13)$$

From (13), the source current supplied by the source, after compensation is

$$i_s(t) = \frac{p_f(t)}{v_s(t)} = i_1 \cos \phi_1 * \sin \omega t = i_m \sin \omega t$$

There are also some switching losses in the PWM converter, and hence the utility must supply a small overhead for the capacitor leakage and converter switching losses in addition to the real power of the load. The total peak current supplied by the source is therefore

$$I_{SP} = I_m + I_{s1} \quad (14)$$

If the active filter provides the total reactive and harmonic power, then $i_s(t)$ will be in phase with the utility voltage and purely sinusoidal. At this time, the active filter must provide the following compensation current:

$$i_c(t) = i_L(t) - i_s(t) \quad (15)$$

Hence, for accurate and instantaneous compensation of reactive and harmonic power it is necessary to estimate, i.e. the fundamental component of the load current as the reference current.

A. SELECTION OF Lc, Vdc, ref and Cdc:

The design of these components is based on the following assumptions:

- The AC source voltage is sinusoidal.

- To design of Lc, the AC side line current distortion is assumed to be 5%.
- Fixed capability of reactive power compensation of the active filter.
- The PWM converter is assumed to operate in the linear modulation mode (i.e. $0 \leq m_a \leq 1$).

As per the compensation principle, the active filter adjusts the current i_{c1} to compensate the reactive power of the load [2]. The three-phase reactive power delivered from the active filter can be calculated from a vector diagram

$$Q_{c1} = 3V_s I_{c1} = \frac{3V_s V_{c1}}{\omega L_c \left(1 - \left(\frac{V_s}{V_{c1}}\right)\right)} \quad (16)$$

i.e. the active filter can compensate the reactive power from the utility only when $V_{c1} > V_s$. If the PWM converter is assumed to operate in the linear modulation mode (i.e. $0 \leq m_a \leq 1$), the amplitude modulation factor m_a is

$$m_a = \frac{v_m}{(V_{dc}/2)}$$

The filter inductor Lc is also used to filter the ripples of the converter current, and hence the design of Lc is based on the principle of harmonic current reduction. The ripple current of the PWM converter can be given in terms of the maximum harmonic voltage, which occurs at the frequency $m_f \omega$:

$$I_{ch(mf\omega)} = \frac{V_{ch(mf\omega)}}{m_f \omega L_c} \quad (17)$$

By solving (16) and (17) simultaneously, the value of Lc, and V_{c1} (i.e. Vdc) can be calculated. V_{c1} , and hence Vdcref, must be set according to the capacity requirement of the system (i.e. $V_s \leq V_{c1} \leq 2V_s$). As the switching frequency is not fixed with the hysteresis controller, a practically feasible value of 10 kHz has been assumed. As per the specification of the peak to peak voltage ripple (Vdc p-p(max)) and rated filter current ($I_{c1, rated}$), the DC side capacitor Cdc can be found from equation

$$C_{dc} = \frac{\pi * I_{c1, rated}}{\sqrt{3} \omega V_{dc, p-p(max)}} \quad (18)$$

PI CONTROL SCHEME:

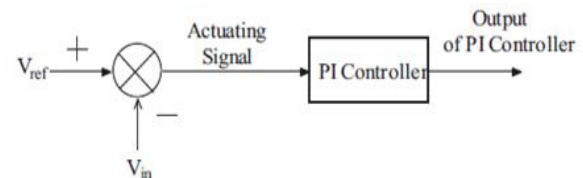

Fig.3 APF Control scheme with PI controller.

The error signal is fed to PI controller. The output of PI controller has been considered as peak value of the reference current. It is further multiplied by the unit sine vectors (u_{sa} , u_{sb} , and u_{sc}) in phase with the source voltages to obtain the reference currents (i_{sa}^* , i_{sb}^* , and i_{sc}^*). These reference currents and actual

currents are given to a hysteresis based, carrier less PWM current controller to generate switching signals of the PWM converter [5]. The difference of reference current template and actual current decides the operation of switches. These switching signals after proper isolation and amplification are given to the switching devices. Due to these switching actions current flows through the filter inductor L_c , to compensate the harmonic current and reactive power of the load, so that only active power drawn from the source.

SIMULATION RESULTS

The shunt active power filter modal is developed and simulate in MATLAB with PWM based PI controller. The complete active power filter system is composed mainly of three-phase source, a non-linear load, a voltage source PWM converter, and a PI controller. A load with highly nonlinear characteristics is considered for the load compensation at PCC. The THD in the load current is 28.05%.

Table 1. System parameters for simulation study

Phase voltage and frequency V	60 V, 50 Hz
line inductance, resistance	7mH, 8 Ω
Coupling inductance	2mH
For VS Type Load resistance, load capacitance	26.66 Ω , 50 μ F
For CS Type Load resistance, load inductance	26.66 Ω , 10mH
For CS Single phase b/w c and n	36.66 Ω , 10mH
Single phase linear load b/w a and n	60 Ω , 10mH
Inverter DC(bus voltage and capacitance	90 V, 3000 μ F
Controller Parameter	$K_p=0.5, K_i=10, K_p=0.8, K_i=12$.

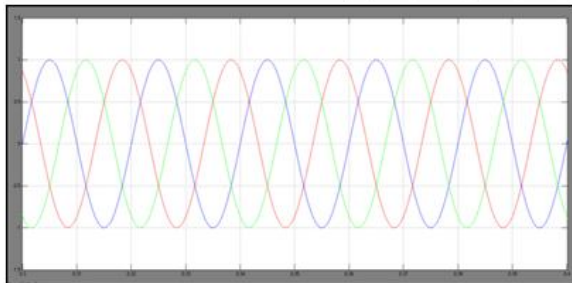

Fig.4 Source Voltage (pu) Waveforms of the System

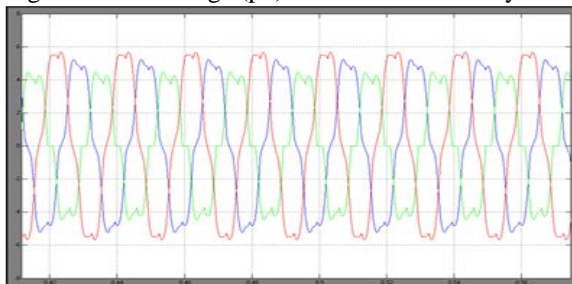

Fig.5 Source Current when the Compensator is not connected.

The compensator is switched ON at $t=0.05s$ and the integral time square error performance index is used coefficients of the PI controller. The optimum

values of K_p and K_i are found to be 0.5 and 10, respectively, which corresponds to the minimum value of ITSE. Compensating currents of PI controllers are shown in figures 6.

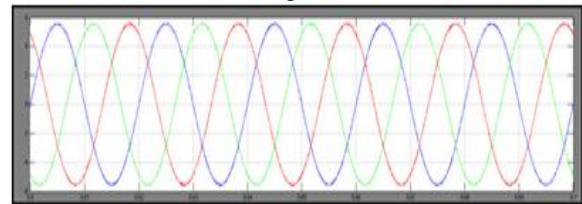

Fig.6 Compensating Current of PI Controller.

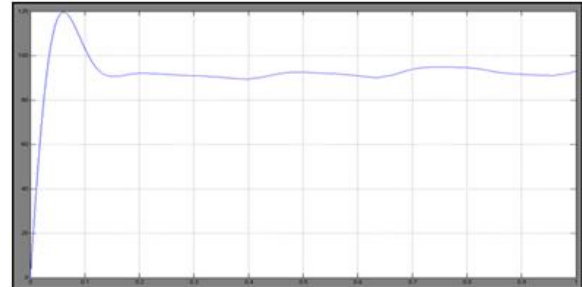

Fig.7 DC Capacitor Voltage During Switch-on Response with PI Controller

From the wave forms it is clear that harmonic distortion is reduced after connecting compensator. The system parameters selected for simulation study are given in table 2 and 3. Figures 8-12 shows the simulation results of the implemented system with PI controller. The source voltage waveform of the reference phase only is shown in figure 4. A diode rectifier with R-L load is taken as non-linear load. The THD of the load current is 24.90%. The optimum values (K_p and K_i) are found to be 0.5 and 10 respectively.

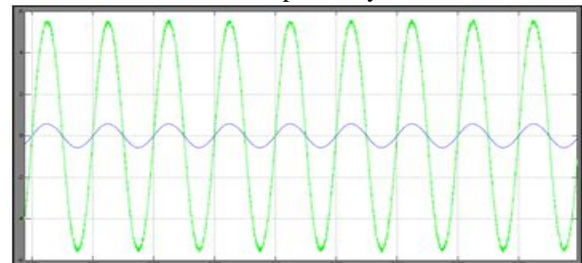

Fig.8 Phase difference between Source Voltage and Current without Compensation

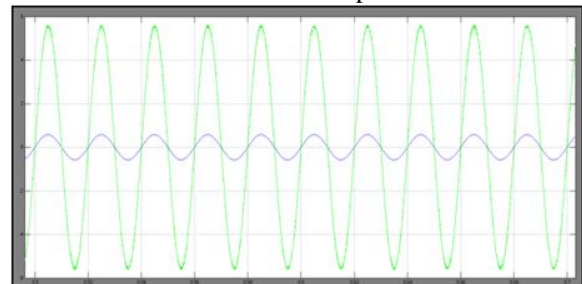

Fig.9 Voltage and Current are in Phase Using pi Controller

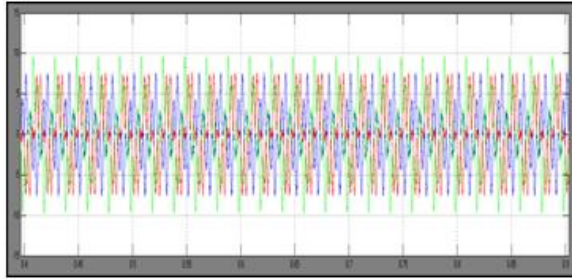

Fig.11 Inverter Currents using PI Controller

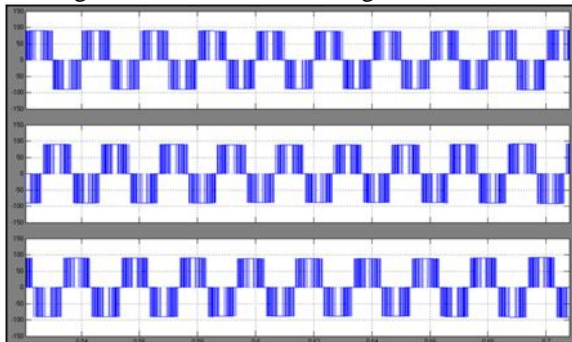

Fig.12 Three phase Voltage Generated by APF

Table 2. Voltage Source Type of Non-Linear Load

Currents	THD(%) before compensation	THD(%) after PI Control
Phase a	12.07	2.65
Phase b	19.47	2.36
Phase b	10.28	2.80

Table 3. Current Source Type of Non-Linear Load

Currents	THD(%) before compensation	THD(%) after compensation PI Control
Phase a	13.76	3.88
Phase b	24.90	4.10
Phase b	12.07	3.04

The settling time required by the PI controller is approximately 8 cycles. The source current THD is reduced near to 4% with PI compensation.

CONCLUSION

In this we are implementing the PI controller which is depend upon the shunt active power filter for harmonic and reactive power compensation of the non-linear load during PCC. Which is found from the simulation results that shunt active power filter which show the improves power quality of the distribution system by eliminating harmonics and reactive power compensation of non-linear load. it have been verified by the simulation results that shunt active power filter improves power quality of the power system by eliminating harmonics and reactive current of the load current. Therefore according to simulation result the THD of the source current is below 5%.

REFERENCES

- [1] C.-S. Lam, M.-C.Wong Y.-D. Han, "Hysteresis current control of hybrid active power filters" Published in IET Power Electronics, doi: 10.1049/iet-pel.2011.0300
- [2] Vinod Khadkikar, "Enhancing Electric Power Quality Using UPQC: A Comprehensive Overview" IEEE Transactions on Power Electronics, Vol. 27, No. 5, May 2012
- [3] S. Orts-Grau, F. J. Gimeno-Sales, A. Abellan-Garcia, S. Segui-Chilet, and J. C. Alfonso-Gil, "Improved Shunt Active Power Compensator for IEEE Standard 1459 Compliance" IEEE Transactions on Power Delivery, Vol. 25, No. 4, October 2010
- [4] Reyes S. Herrera and Patricio Salmeron, "Instantaneous Reactive Power Theory: A Comparative Evaluation of Different Formulations" IEEE Transactions On Power Delivery, Vol. 22, No. 1, January 2007
- [5] Reyes S. Herrera, Patricio Salmeron, and Hyosung Kim, "Instantaneous Reactive Power Theory Applied to Active Power Filter Compensation: Different Approaches, Assessment, and Experimental Results" IEEE Transactions On Industrial Electronics, Vol. 55, No. 1, January 2008
- [6] Yunwei Li, D. Mahinda Vilathgamuwa and Poh Chiang Loh, "Microgrid Power Quality Enhancement Using a Three-Phase Four-Wire Grid-Interfacing Compensator" IEEE Transactions On Industry Applications, Vol. 41, No. 6, November/December 2005
- [7] A.Elmitwally, SAbdelkader and M.EI-Kateb, "Neural network controlled three-phase four-wire shunt active power filter" IEEE Power Generation & transmission Vol. 147, NO.2 March 2000
- [8] J. A. Barrado, R. Grino and H. Valderrama-Blavi, "Power-Quality Improvement of a Stand-Alone Induction Generator Using a STATCOM With Battery Energy Storage System" IEEE Transactions On Power Delivery, Vol. 25, No. 4, October 2010
- [9] Rade M. Ciric, Antonio Padilha Feltrin, and Luis F. Ochoa, "Power Flow in Four-Wire Distribution Networks—General Approach" IEEE Transactions On Power Systems, Vol. 18, No. 4, November 2003
- [10] P. Salmeron, J. C. Montano, J. R. Vazquez, J. Prieto, and A. Perez, "Compensation in Nonsinusoidal, Unbalanced Three-Phase Four-Wire Systems With Active Power-Line Conditioner" IEEE Transactions On Power Delivery, Vol. 19, No. 4, October 2004